

Fulflo® FB Filter Vessels

- Carbon Steel
- 304L and 316L Stainless Steel

Bag Filter Vessel Series

FB Model Bag Filter Vessels Designed for Economical Filtration of Liquids and Gases

Applications

- Potable Water
- Process Water
- Edible Oils
- Coatings
- Lubricants
- Coolants
- Cutting Oils
- Solvents



Features and Benefits

- Single O-ring design closure assures quick, positive cover sealing. (O-rings are not required to seal filter bags.)
- Swing bolts with eyenuts for fast, easy opening and closing of cover.
- Buna-N O-ring standard with EPR, Viton* and fluoropolymer available.
- Maximum design pressure is 150 psi (10.3 bar) at 450°F** (232°C).
- ASME Code UM stamp is standard (U stamp is optional).
- Threaded vent and drain connections.
- Adjustable leg height. Threaded or flanged inlet and outlet.
- Side inlet; cover opens without disconnecting piping.
- Side inlet, bottom outlet and crevice-free welded design provide a smooth interior for easy wash-out and cleaning.
- Hinged cover for easy opening.
- Positive seal of "C" style flex band bags prior to closing the vessel cover.
- Optional hold-down assembly for conversion to "G" style bag media seal available.

Process Filtration Division



Bag Filter Vessel Series

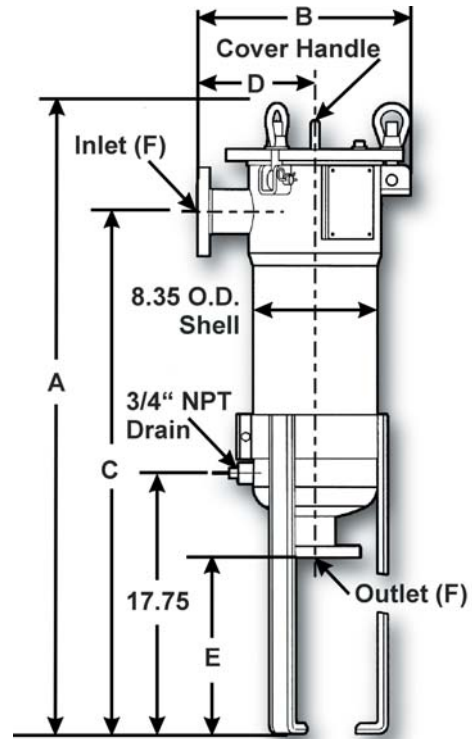
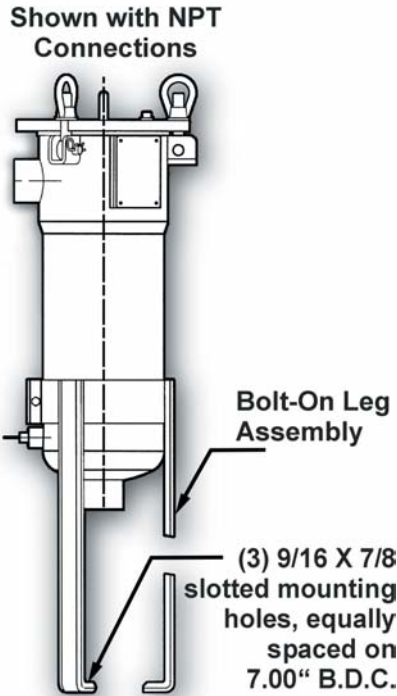
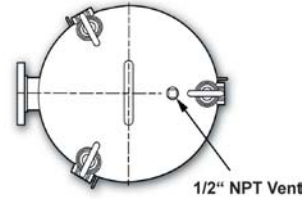

Design Specifications

Model	Bag Style	Typical Aqueous Flow† (gpm)	Dimensions (in)					Shipping Weight (lbs)	Volume (gal)	
			A	B	C	D	E			F
FB11-2	Single	80	43.06	12.25	35.63	5.75	13.19	2NPT	90	5.4
FB11-2F	Single	80	43.06	14.50	35.63	8.00	12.00	2NPS	100	5.4
FB12-2	Double	160	53.94	12.25	46.50	5.75	13.19	2NPT	95	7.8
FB12-2F	Double	160	53.94	14.50	46.50	8.00	12.00	2NPS	105	7.8
FB12-3F	Double	160	53.94	14.50	46.50	8.00	11.75	3NPS	115	7.8

† Actual flow rate is dependent on fluid viscosity, micron rating, contaminant and media type. Consult flow charts for each application.

Ordering Information

4L	FB	11	—	2F
Material	Model	Media Requirement		Inlet/Outlet Flange Size
No Symbol = Carbon Steel		11 = One Single Bag		2
4L = 304L Stainless Steel		12 = One Double Bag		3
6L = 316L Stainless Steel				No F = NPT

Process Filtration Division

* A trademark of E. I. du Pont de Nemours & Co.
 ** Operating temperature limited to 250°F (121°C) by standard Buna-N O-ring and exterior paint on carbon steel models. Optional O-ring materials are available.

Parker Hannifin Corporation
 Process Filtration Division
 6640 Intech Boulevard
 Indianapolis, Indiana 46278
 Toll Free 1-888-C-FULFLO (238-5356)
 Telephone (317) 275-8300
 Fax (317) 275-8410
<http://www.parker.com>

